

TROUBLESHOOTING

- **PULSATING FLOW– PUMP CYCLES ON AND OFF**

- Check lines for kinks.
- Plumbing lines or fittings may be too small.
- Clean faucets and filters.
- Check fitting tightness for air leaks.

- **FAILURE TO PRIME BUT MOTOR OPERATES - NO PUMP DISCHARGE**

- Restricted intake or discharge line.
- Air leak in intake line.
- Punctured pump diaphragm.
- Initial amp supply is not enough to sufficiently start the motor.
- Debris clogged in the valves.
- Crack in pump housing.

- **MOTOR FAILS TO TURN ON**

- Loose or improper wiring.
- Pump circuit has no power.
- Blown fuse or thermal protection tripped.
- Failed pressure switch.
- Defective motor.

- **PUMP FAILS TO TURN OFF AFTER ALL FIXTURES ARE CLOSED**

- Punctured diaphragm.
- Discharge line leak.
- Defective pressure switch.
- Insufficient voltage.
- Clogged valves in pump head.

- **LOW FLOW AND PRESSURE**

- Air leak at pump intake.
- Accumulation of debris inside pump or plumbing.
- Worn pump bearing (possibly accompanied by loud noise).
- Punctured diaphragm.
- Defective motor.

- **NOISY**

- Check if the mounting feet are compressed too tightly.
- Is the mounting surface flexible? If so, it may be adding noise.
- Check for loose head/screws.
- If the pump is plumbed with rigid pipe, then it may transmit noise more easily.

CAUTION

Please do follow the instruction manual to install the product. Any action outside what is recommended in this manual may bring damage to the pump. Any inappropriate installation or operation that causes the pump damage is not covered by warranty.

SEAFLO®

Washdown Pump Kit Installation Manual



Our heavy-duty washdown kit. The best choice for cleaning boats, fish boxes, anchor wells, dinghies, and other similar applications. This pump boasts a huge capacity and has an on-demand switch, so the pump automatically turns on when you squeeze the spray gun handle. With 70 PSI cutoff, this has the pressure to get rid of stubborn debris. Suitable for fresh and saltwater applications.

FEATURE & BENEFIT

- 5 Independent chambers
- Self-Priming up to 1.83 m/6 feet
- Spray gun range 10 m/32.81 feet
- The best choice for cleaning boats, fish boxes, anchor wells, dinghies, and other similar applications
- Run dry capability
- Continuous duty
- Anticorrosive stoving varnish coated motor

STANDARD CONFIGURATIONS

Model	Voltage	Open Flow (GPM/LPM)	Control Type	Max Draw	Shut-off Pressure (PSI/BAR)	Valves	Diaphragm	Ports	Wire Connections
SFWP1-050-070-51 NEW	12V	5.0 / 18.9	Switch	17.0	70 / 4.8	EPDM	Santoprene	1/2"-14MNPT	2-Pin/Leads
SFWP1-055-070-51 NEW	12V	5.5 / 20.0	Switch	17.0	70 / 4.8	EPDM	Santoprene	1/2"-14MNPT	2-Pin/Leads
SFWP2-050-070-51 NEW	24V	5.0 / 18.9	Switch	10.0	70 / 4.8	EPDM	Santoprene	1/2"-14MNPT	2-Pin/Leads
SFWP2-055-070-51 NEW	24V	5.5 / 20.0	Switch	10.0	70 / 4.8	EPDM	Santoprene	1/2"-14MNPT	2-Pin/Leads

INSTALLATION MANUAL SETUP

1. Do not apply inlet pressure in excess of 30 psi. In general, try to avoid any inlet pressure completely.
2. Strainer should be attached to the inlet side.
3. The fittings must be secured to avoid leakage.
4. Connect the positive lead (red) to the positive terminal of your battery and the negative wire (black) to the negative terminal of your battery.
5. As the water supply pump is non-essential, reference the wire chart under the electrical information. Be sure to have the correct wire sizing for the length of wire you are using.
6. After installation, check the voltage at the pump motor. Voltage should be checked when pump is operating. Full voltage must be available at the pump motor at all times.

INSTALLATION DIAGRAM

A

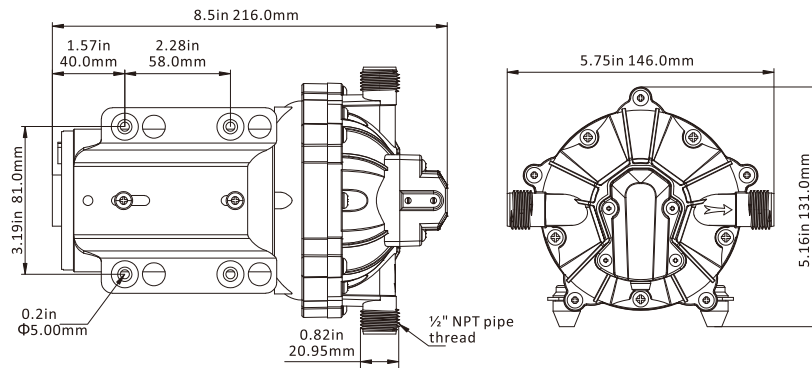

B

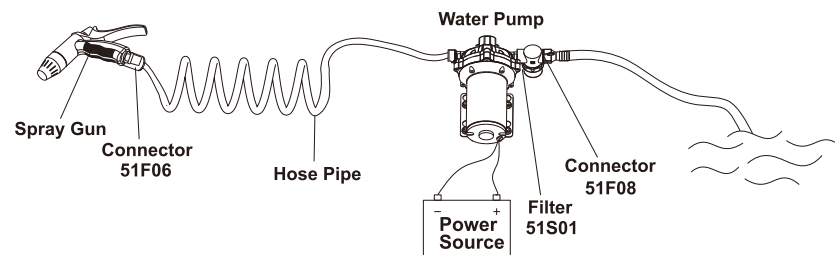

ACCESSORY

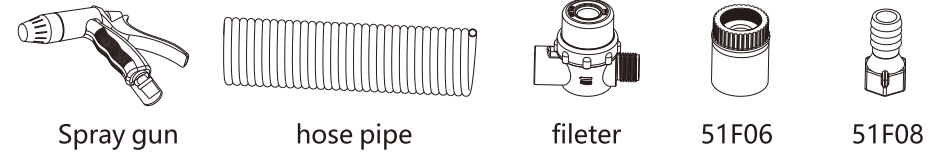

REPAIR KITS

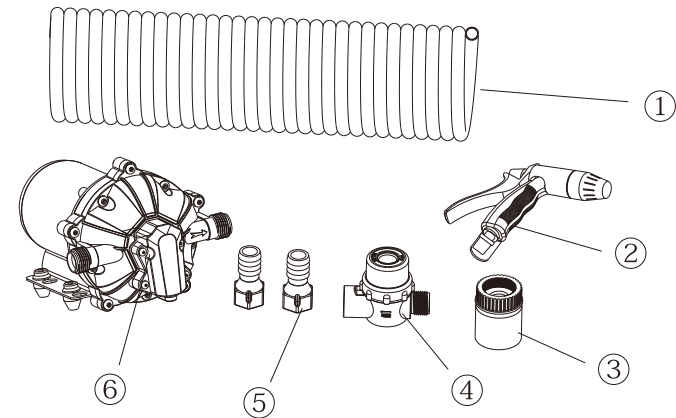

NO.	NAME	MATERIAL	WET PART	QUANTITY
1	SPRING TUBE	PU	YES	1
2	SPRAY GUN	ABS	YES	1
3	51F06	ABS	YES	1
4	51S01 FILTER	PP+20%GF&PC	YES	1
5	51F08	POM&PP	YES	2
6	51SERIES WATER PUMP	SFDP1-055-060-51 NEW	YES	1

MAINTANCE

Lack of sanitizing and maintenance is one of the main reasons of under performance of the pump. Please do maintenance and winterize the pump at appropriate times, especially before and after a period of storage.